

# Door Entry Direct

## ES9000 Series Pre-Load Strike

### General Description

The ES9000 has been designed to suit the harshest commercial environments, and has the unique feature of the ability to operate with up to 25kg of pre-load pressure on the keeper. Pre-load is a common condition that caused by pulling on a door before it unlocks, the weight of warped or drooping doors, seals on fire doors, or by differential air pressure created when heating and cooling systems are in use.

Standard features include multi voltage 10 - 30Vdc and field changeable settings from fail safe to fail secure.

Built to last, this is a premium locking solution that has been tested in excess of 2 million cycles and boasts unique features like no other available on the market today.

### Key Features

- Operates under pre load up to 25kg
- Easy field selectable fail safe/fail secure
- Multi voltage 10-30Vdc
- 1300kg holding force
- 2.5 million cycles endurance rating
- Latch keeper is significantly quieter in operation
- Weather resistant
- Mounting tabs as standard
- Non handed
- Australian designed and made
- **TRIMEC** 5 Year Warranty

### Applications

- High traffic areas
- Doors subjected to side load (pre load)
- Fire rated door sets
- Open in/open out doors
- Suitable for use with all access control systems



### Standards and Compliance

S3 (Security) Australian Lock Standard (AS4145.2.1993)

D3 (Durability) Australian Lock Standard (AS4145.2.1993)



Successfully fire rated up to 4hrs on fire door assemblies in accordance with AS1905.1.2005 (Part 1: Fire resistant door sets)



CE Approved

# Door Entry Direct

## ES9000 Series Pre-Load Strike

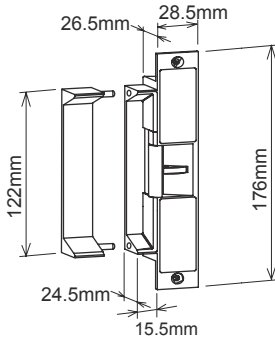

ES9000 with 25mm Extension Lip

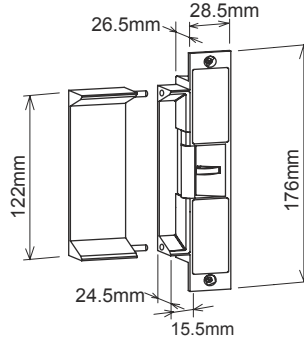

ES9000 with 50mm Extension Lip

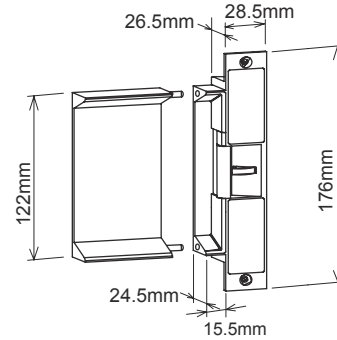

ES9000 with 75mm Extension Lip

### ES9000 Pre-Load Strike Technical Information

Voltage	10 –30Vdc
Current	250mA @12Vdc –130mA @24Vdc
Solenoids	Solenoid rated for continuous use.
Electrical protection	Polarity and back EMF protected
Monitoring	Solenoid Monitor - 1 amp NO/NC microswitch Door / Latch - 1 amp NO/NC microswitch
Holding Force	1300kg static strength rating
Endurance	1,200,000 cycles endurance rating @ 25kg pre-load 2,500,000 cycles general durability without pre-load conditions
Latching	Suitable for 15mm latch with 3mm door gap
Environment	Operational temperature range -20°C to +60°C
Body	Solid Stainless Steel Construction
Keeper	Stainless Steel

### Ordering Information

Product Description	Part Number
ES9000 Pre - Load Multi Function Strike	119001-000
ES9000 Pre - Load Multi Function Strike - No Extension Lip	119001-010
ES9000 Pre - Load Multi Function Strike - 8mm Extension Lip	119001-020
ES9000 Pre - Load Multi Function Strike - with Extension Lip Holes	119001-060

Note: All ES9000 series electric strikes are supplied in Fail Safe configuration.

### Specification Statement

The electric strike should be fully monitored and have independent door / latch and solenoid monitor switches. Holding force for the strike should be not less than 1300kg.

Where Power to Lock and Power to Open functions may be required in the same building, a single electric strike should be interchangeable from either fail safe or fail secure from the rear of the strike.

The electric strike should not consume current greater than 250mA @ 12Vdc and have a solenoid rated for continuous use. A fire rating not less than 4 hours is required where applicable. The strike must be capable of operating with up to 25kg of pre-load pressure applied to the keeper, be tested to 2.5 million operations and carry a minimum warranty of 5 years.